

SCHIEBETÜRSYSTEM 120 HOLZ SOFTEINZUG 1-FLG.

A: SICHERHEITSHINWEISE

SAFETY ADVICES

B: MONTAGE, PFLEGE UND WARTUNG

ASSEMBLY, CARE INSTRUCTIONS, SERVICE AND MAINTENANCE

Passende Schiebetürsysteme / matching sliding door systems

Art. Nr.: .. 403 07 01 ..
 .. 403 07 02 ..
 .. 403 12 01 ..
 .. 403 12 02 ..

A

Sicherheitshinweise:

D

Wichtige Sicherheitshinweise für die Montage und Nutzung von Schiebetürsystemen

(Zusätzlich zu Montage- und Bedienungsanleitung zu beachten, um Schäden an Produkt sowie Personen- und Sachschäden zu vermeiden.)

Wichtig: Alle Nutzer sind über die sie betreffenden Punkte der nachfolgenden Hinweise sowie die Hinweise aus Montage- bzw. Bedienungsanleitung zu informieren!

Allgemein:

- Schiebetüren dürfen nicht zu hart zu- oder aufgezogen werden. Dies trifft vor allem auf Schiebetüren ohne Softeinzug zu.

Montage:

- Mitgeliefertes Befestigungsmaterial ist auf Kompatibilität mit den vorhandenen Untergründen zu prüfen. Gegebenenfalls muss geeignetes Befestigungsmaterial selbst besorgt werden.
- Vor der Montage müssen die Klemmflächen mit fettlösenden Haushaltsmitteln von Fetten befreit werden.
- Es besteht die Gefahr von Quetschungen beim Heben der Tür. Entsprechend ist erforderliche Schutzkleidung zu tragen.

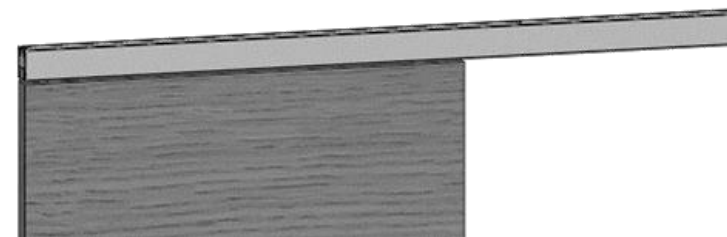

Safety advices:

GB

Important safety-related information for the mounting and use of sliding door systems

(Follow these instructions in addition to the mounting and operating instructions in order to avoid damage of product and damage to person or property.)

Important: All users have to be informed about relevant points mentioned in following safety advices and installation and operating instructions!

General information:

- Do not shut sliding doors with excessive force. This is especially important on sliding doors without soft closing device.

Assembly:

- Included mounting material must be checked for compatibility with the existing wall and ceiling. If required, suitable mounting material must be purchased.
- Clean clamping areas with fat solvent (standard commercial cleaning agent) before mounting.
- There is a danger of bruising when lifting the door. Wearing protective clothing is required.

B Montage, Pflege und Wartung

Wichtige Informationen:

- Maximal zulässiges Gewicht der Tür beträgt 80kg.
- Maximal zulässige Türstärke beträgt 40mm.
- Minimale Holztürbreite beträgt 850mm.
- Vor der Montage müssen die Klemmflächen mit fettlösenden Haushaltsmitteln von Fetten befreit werden.
- Mitgeliefertes Befestigungsmaterial ist auf Kompatibilität zu den vorhandenen Untergründen zu prüfen. Gegebenenfalls muss geeignetes Befestigungsmaterial selbst besorgt werden.

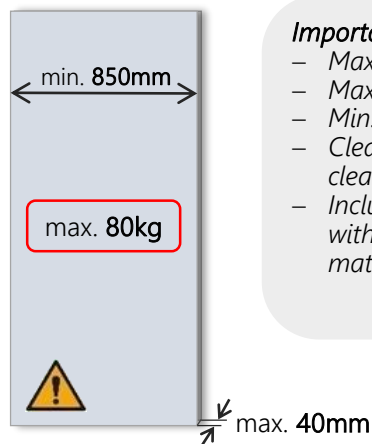

Assembly, care instructions, service and maintenance

Important information:

- Max. permissible weight of the door is 80kg.
- Max. permissible door thickness is 40mm.
- Min. wooden door width is 850mm.
- Clean clamping areas with fat solvent (standard commercial cleaning agent) before mounting.
- Included mounting material must be checked for compatibility with the existing wall and ceiling. If needed, suitable mounting material must be purchased.

Wartung:

- Der Sitz und die Gängigkeit der geklemmten Teile sowie die Justierung der Tür müssen regelmäßig kontrolliert werden. Insbesondere im Falle von hochfrequentierten Anlagen sollte die Prüfung von einem Fach- oder Installationsbetrieb erfolgen.
- Die Reinigung der Metall-Oberflächen (z.B. Schienen) darf nur mit geeigneten Reinigern und Pflegemitteln erfolgen.

Pflege allgemein:

Die Oberflächen der Schiebetürsysteme sind nicht wartungsfrei und sollten gemäß ihrer Ausführung gereinigt werden.

- Für metallische Oberflächen (Eloxal-/Edelstahloberfläche) bitte nur geeignete Reiniger ohne Scheuermittelanteil verwenden.
- Für lackierte Oberflächen bitte nur entsprechende lösemittelfreie Reiniger verwenden.

Maintenance:

- Check clamped parts at regular intervals for proper positioning and smooth running and door for correct adjustment. Especially highly frequented door systems require inspection by properly qualified staff (specialized companies or installation firms).
- Only use suitable cleaning and care products to clean the metallic surfaces (e.g. rails).

General care instructions:

The surface finishes of the sliding door systems are not maintenance-free and should be cleaned according to their material and texture.

- For metallic surfaces (anodized/stainless steel finish) please only use appropriate cleaning agents without abrasive additives.
- For varnished surfaces please only use appropriate solvent-free cleaning agents.

SCHIEBETÜRSYSTEM 120 HOLZ SOFTEINZUG 1-FLG.

Wandbefestigung / wall mounting

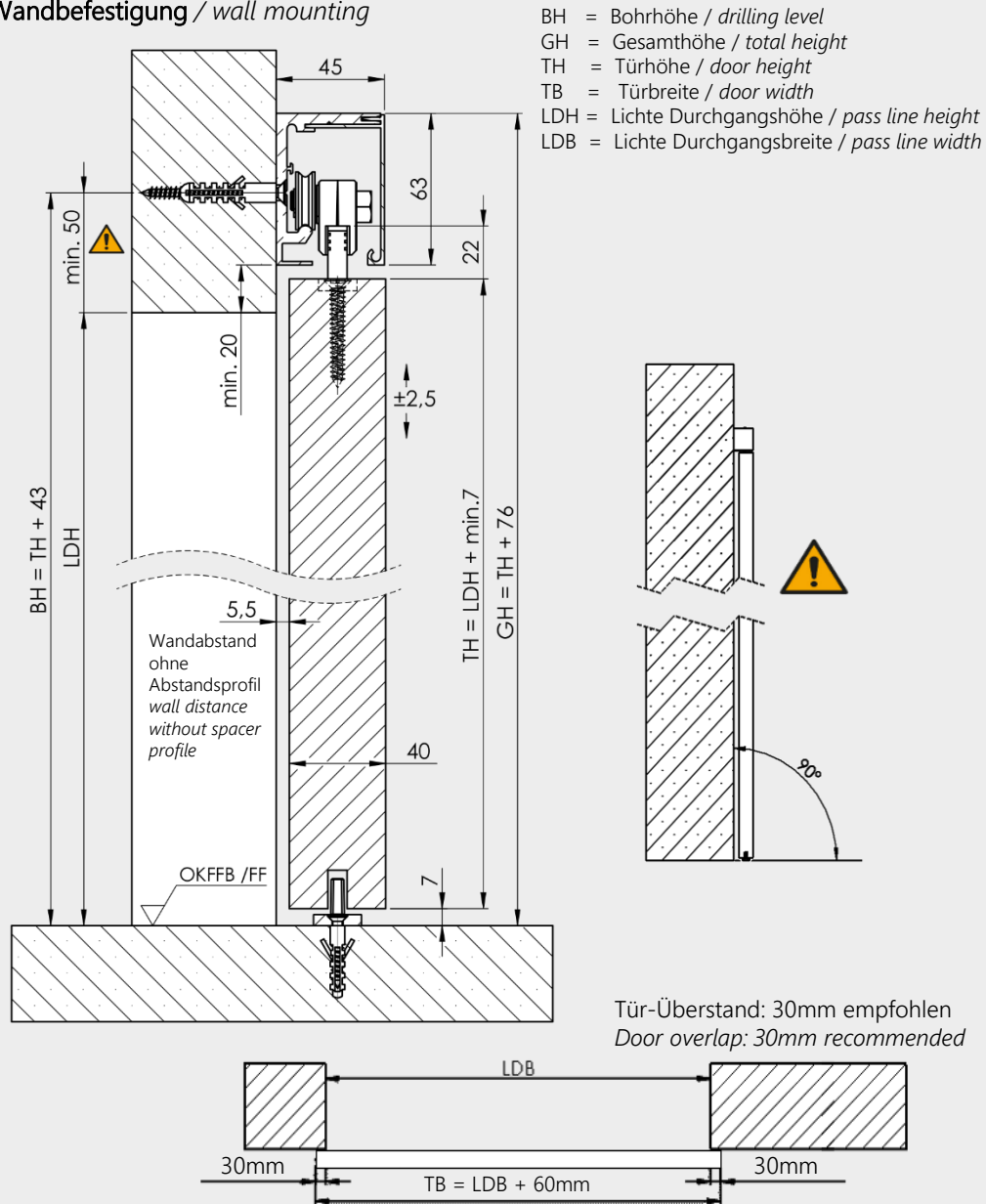

1

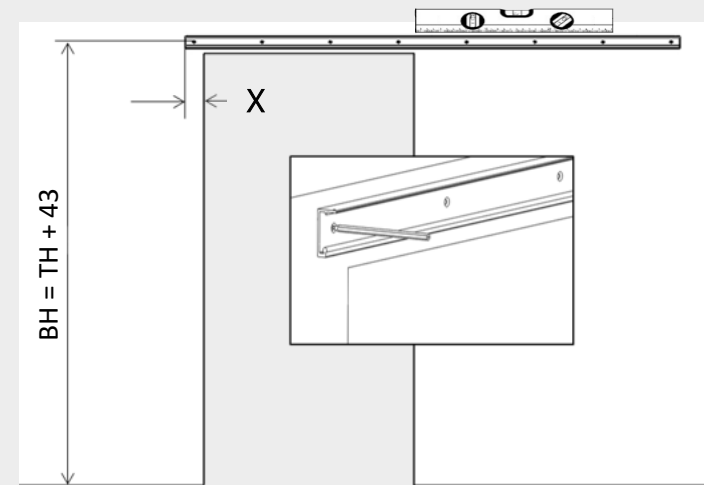

X = Tür-Überstand / door overlap + 1mm
 Empfohlen / recommended: X = 31mm

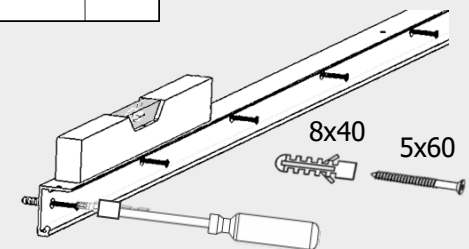
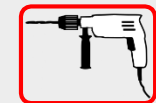
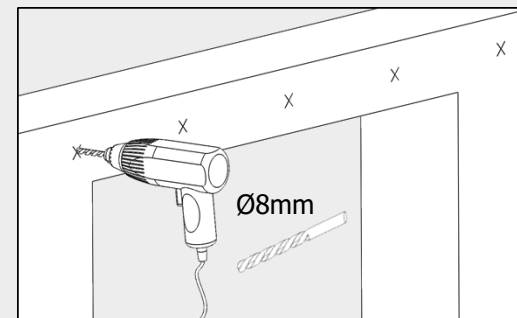

SCHIEBETÜRSYSTEM 120 HOLZ SOFTEINZUG 1-FLG.

Deckenbefestigung / ceiling mounting

TH = Türhöhe / door height
 TB = Türbreite / door width
 LDH = Lichte Durchgangshöhe / pass line height
 LDB = Lichte Durchgangsbreite / pass line width

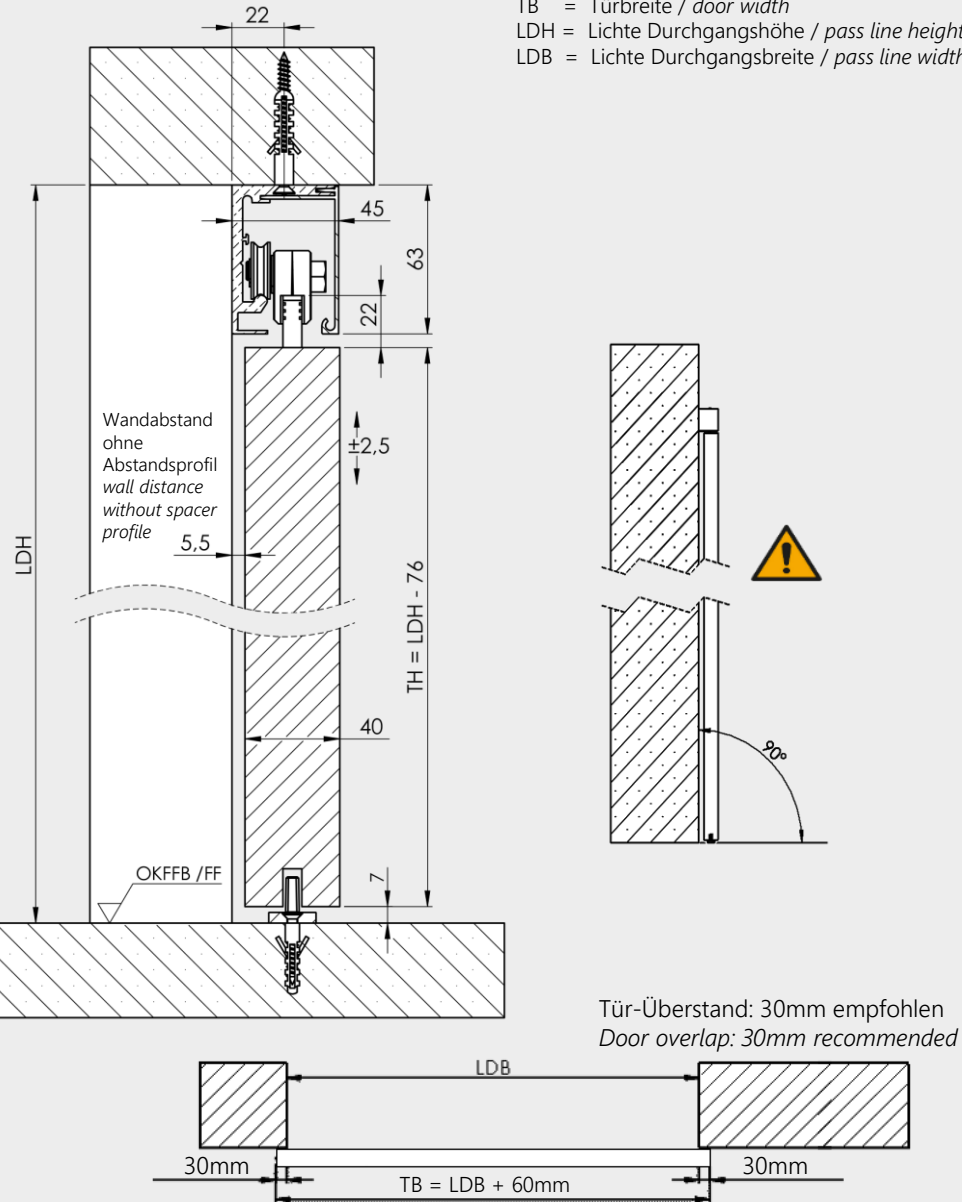

Tür-Überstand: 30mm empfohlen
 Door overlap: 30mm recommended

1

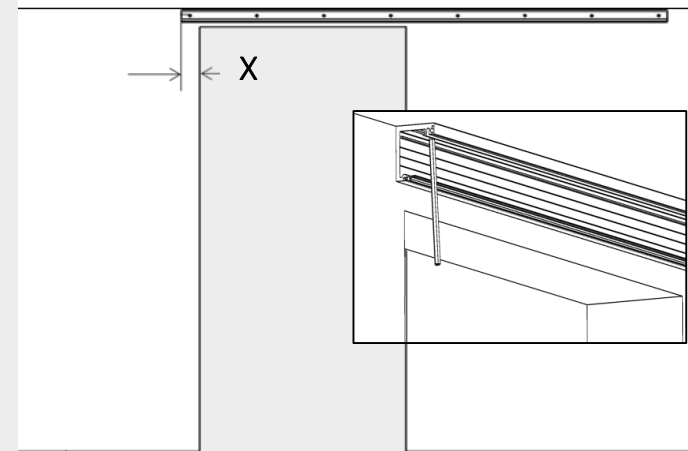

$X = \text{Tür-Überstand} / \text{door overlap} + 1mm$
 Empfohlen / recommended: $X = 31mm$

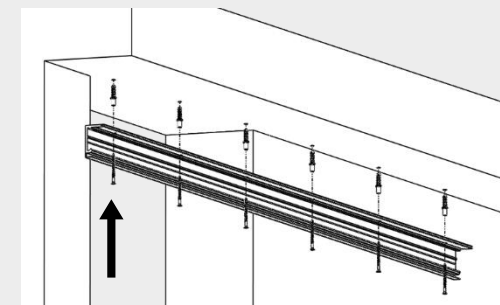
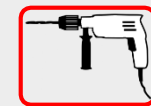
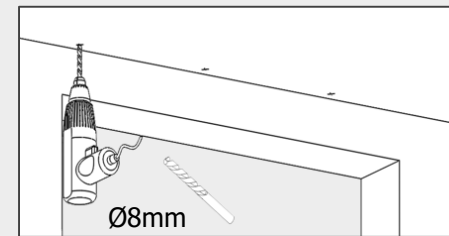

SCHIEBETÜRSYSTEM 120 HOLZ SOFTEINZUG 1-FLG.

2

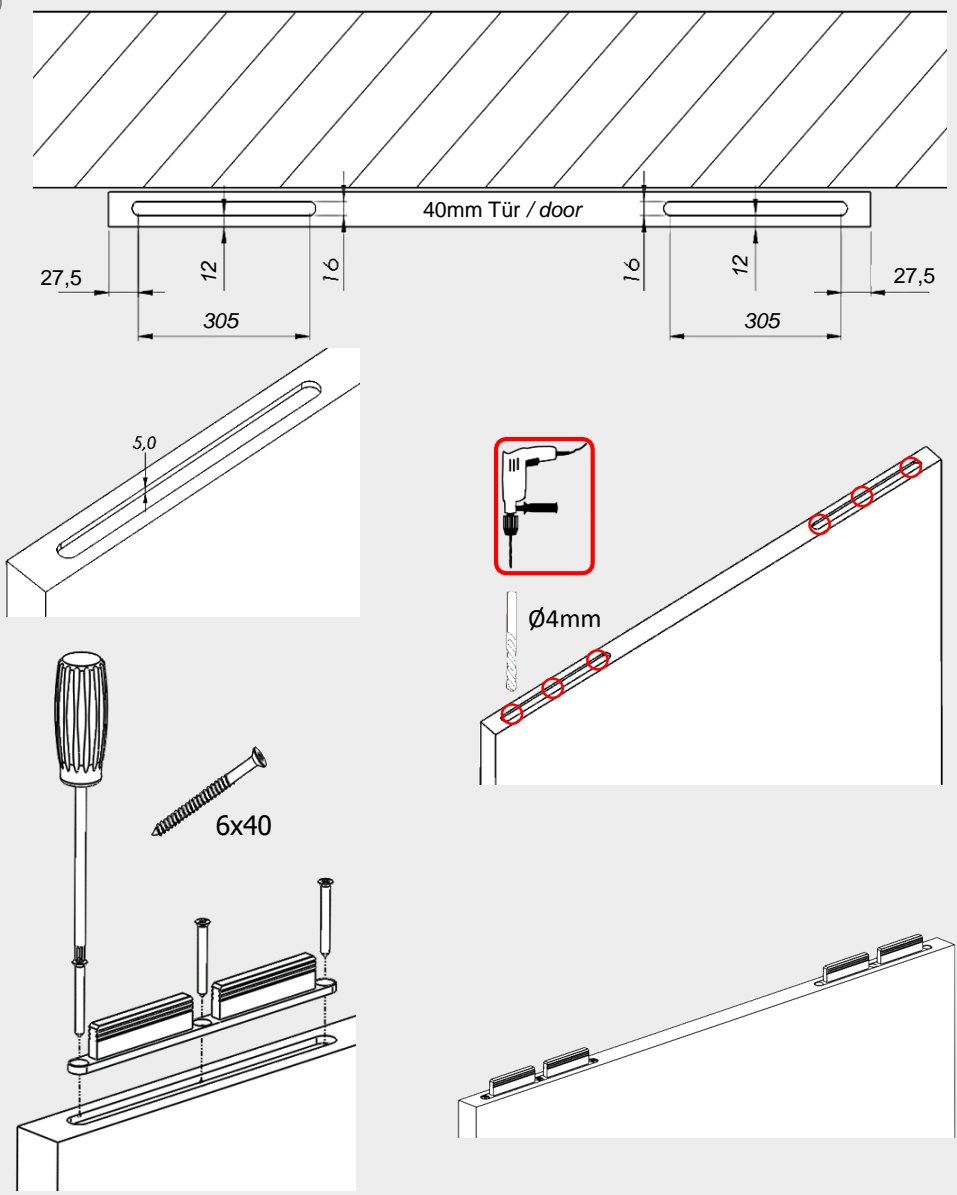

3

Montage Softeinzug-Aktivator / mounting soft stop activator

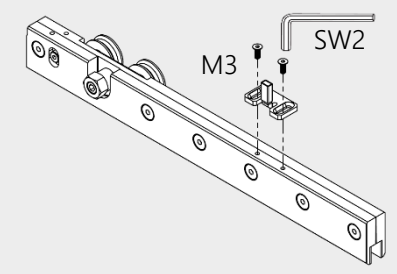

4

Schraube der Aushängesicherung lösen und nach unten schieben.
Loosen the screw of the safety catch slightly and slide it downwards.

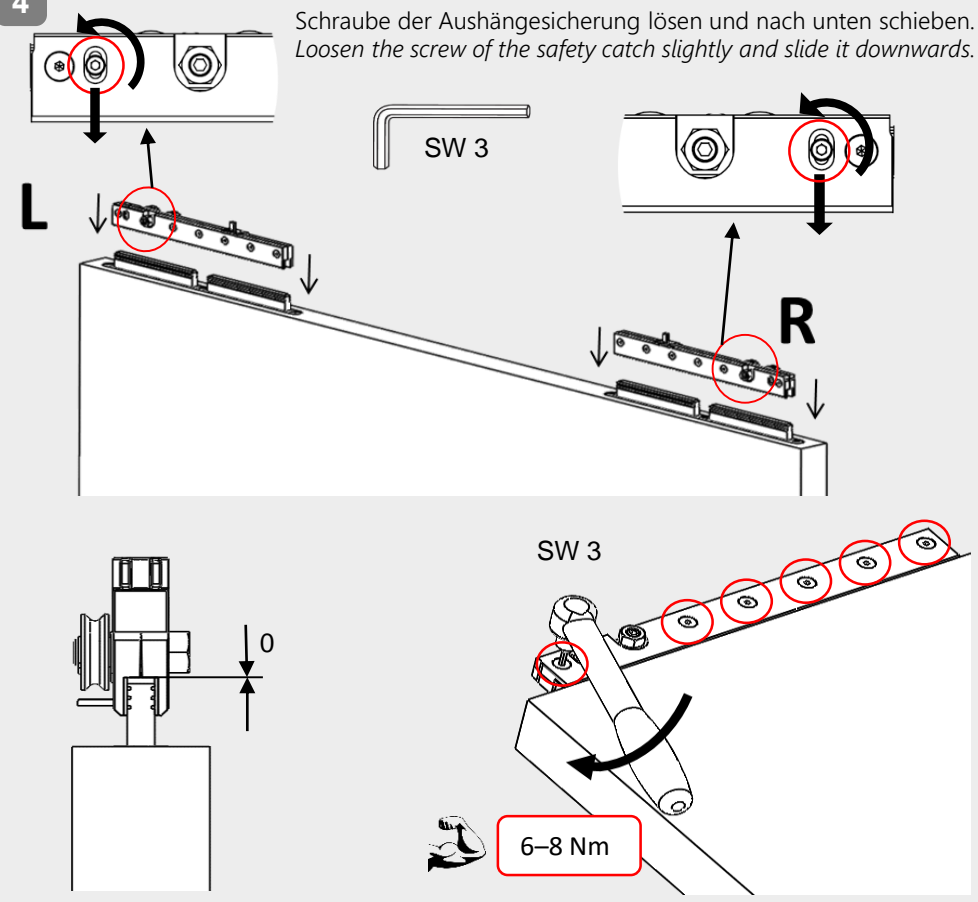

SCHIEBETÜRSYSTEM 120 HOLZ SOFTEINZUG 1-FLG.

5 Bodenführung / floor guidance

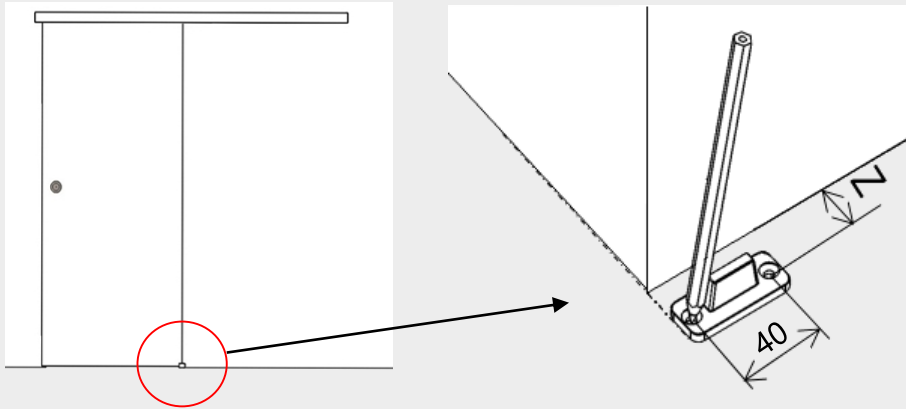

$Z = 25,5\text{mm}$

Ohne Abstandsprofil (ggf. Maß des Abstandsprofils addieren)
Without spacer profile (if applicable, add thickness of the spacer profile)

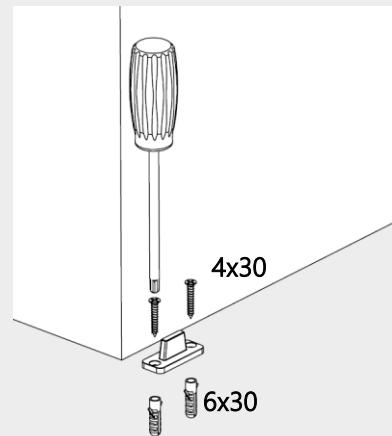
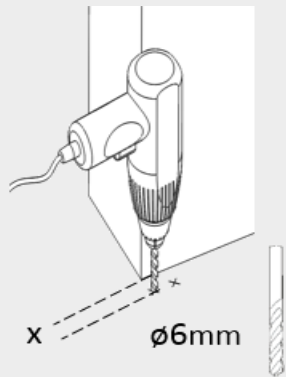

6

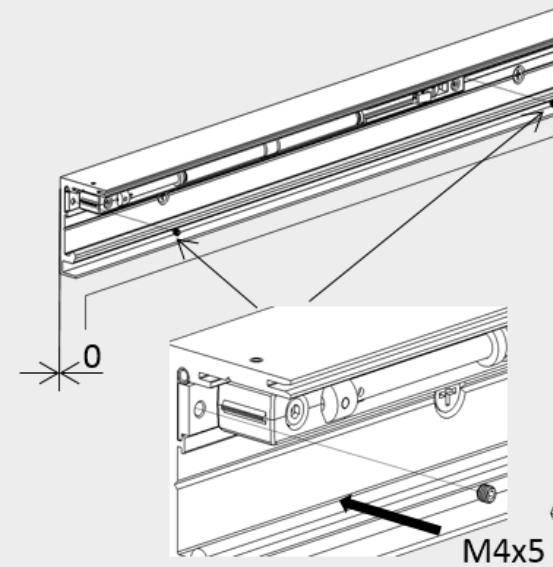
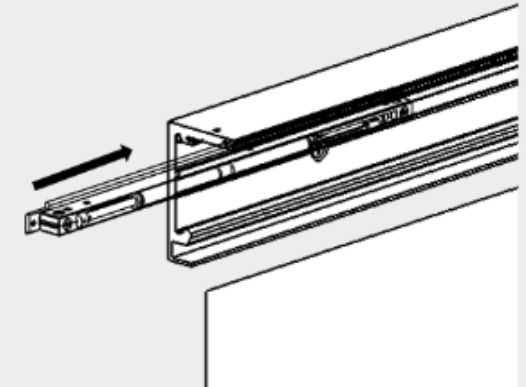

SW 2

3-4 Nm

SCHIEBETÜRSYSTEM 120 HOLZ SOFTEINZUG 1-FLG.

7

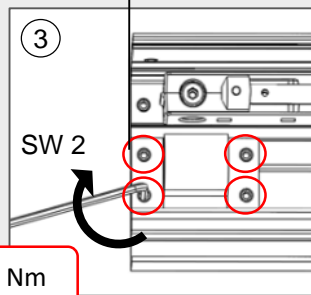
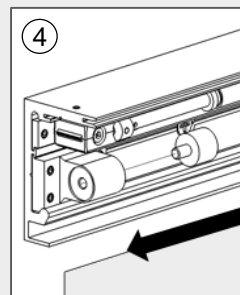
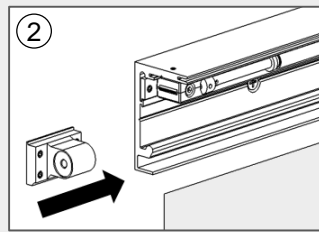
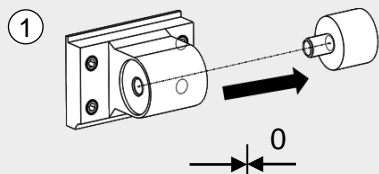

3-4 Nm

8

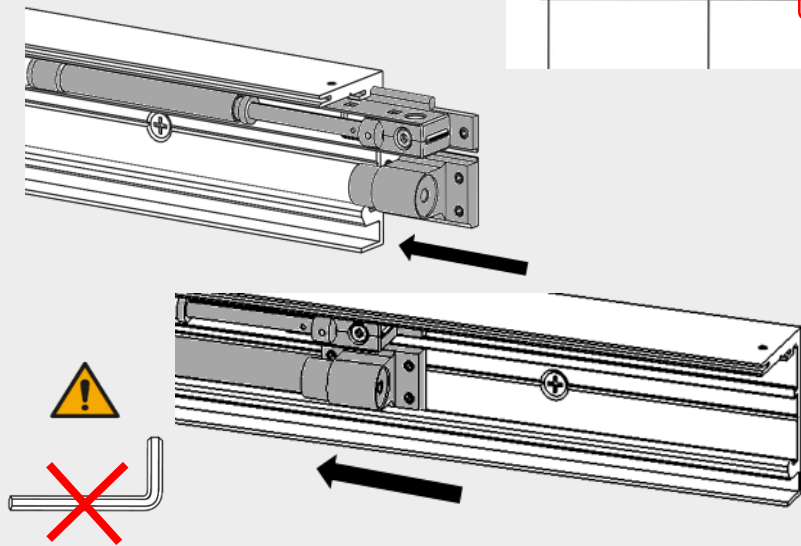

9

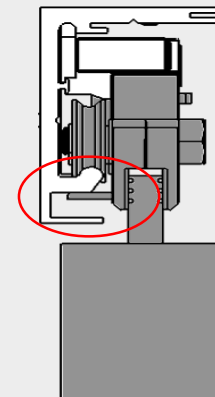
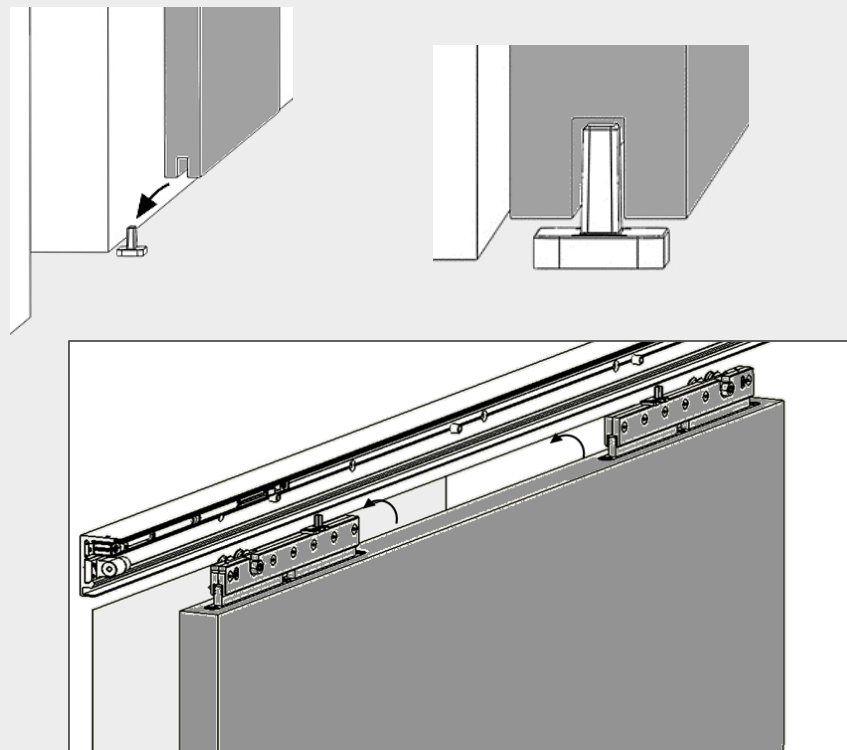

SCHIEBETÜRSYSTEM 120 HOLZ SOFTEINZUG 1-FLG.

10

Höhenverstellung
height adjustment

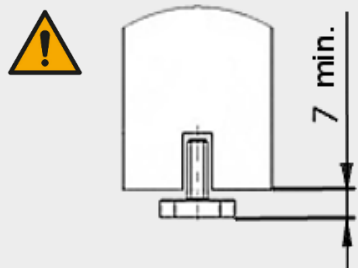
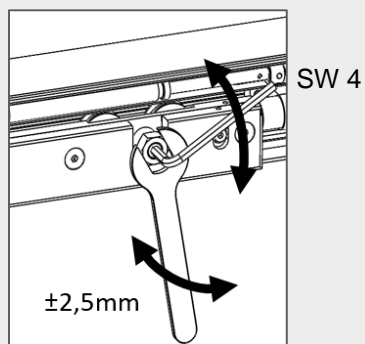
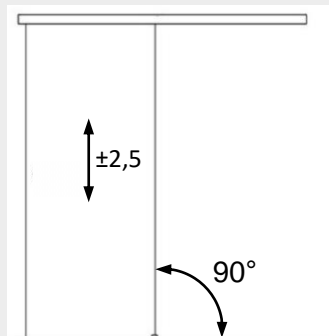

11

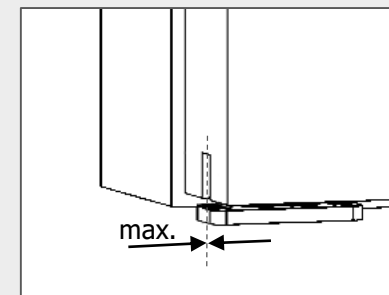
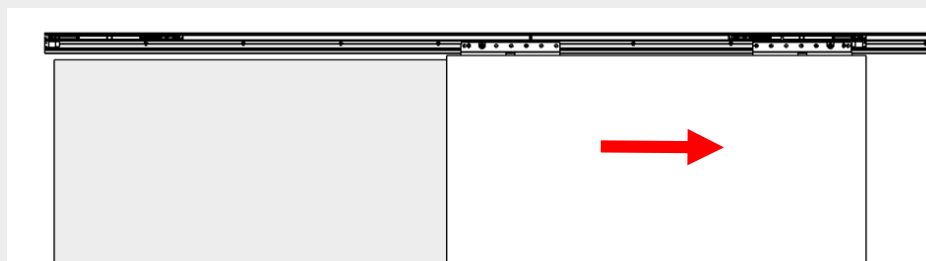

Ggf. Griffstangen/Griffmuscheln auf Innenseite berücksichtigen und Endposition der Tür entsprechend wählen!
If applicable, keep pull handles/finger pulls inside in mind and choose endposition of door accordingly!



Einschnappen
snap into place



3-4 Nm

SW 2

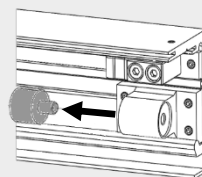
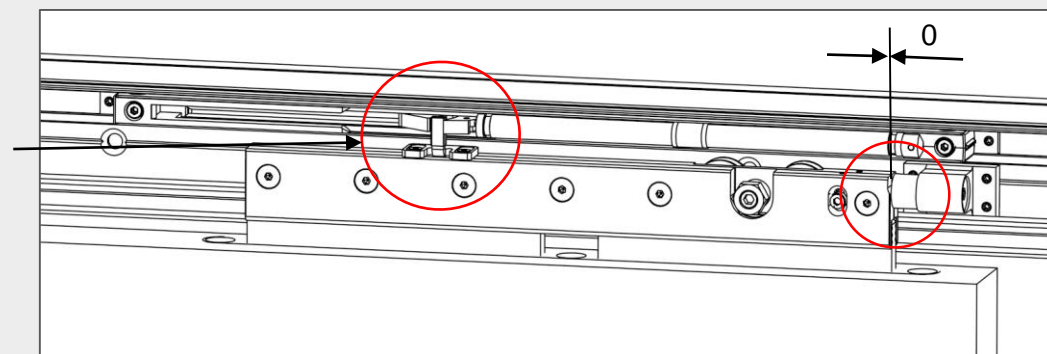

1

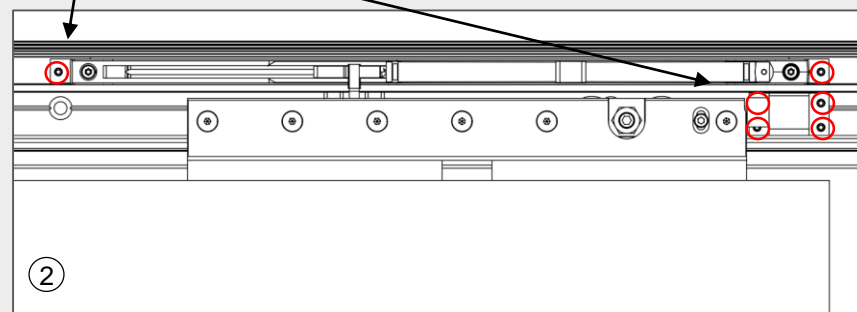

2

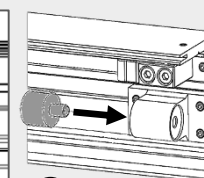

3

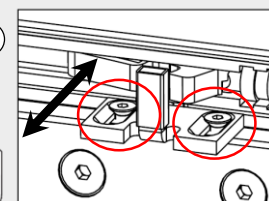

4

Falls nötig, anpassen.
Adjust if necessary.

SW 2

SCHIEBETÜRSYSTEM 120 HOLZ SOFTEINZUG 1-FLG.

12 Aushebesicherung / safety catch

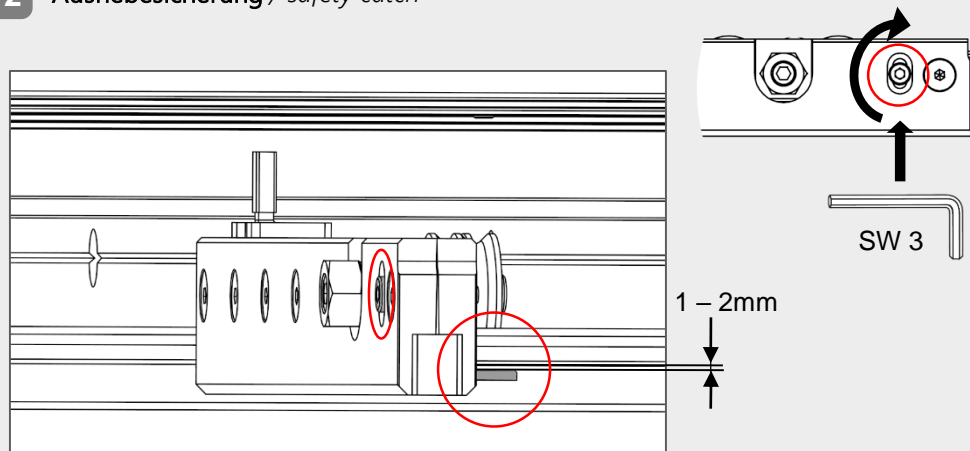

Abstand der Aushebesicherung zum Aluprofil auf 1-2mm einstellen und festziehen.
Adjust the distance of the safety catch to the aluminum profile to 1-2mm and tighten it.

13

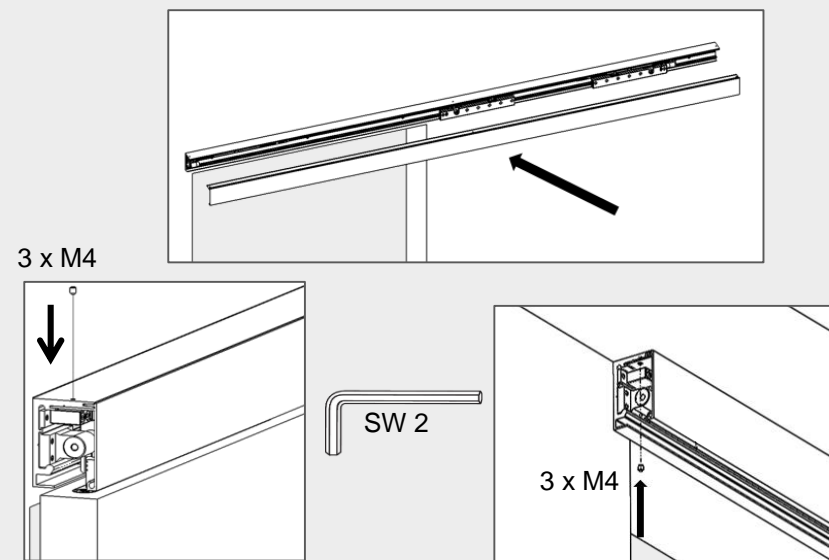

Wandbefestigung / wall mounting

Deckenbefestigung / ceiling mounting

14

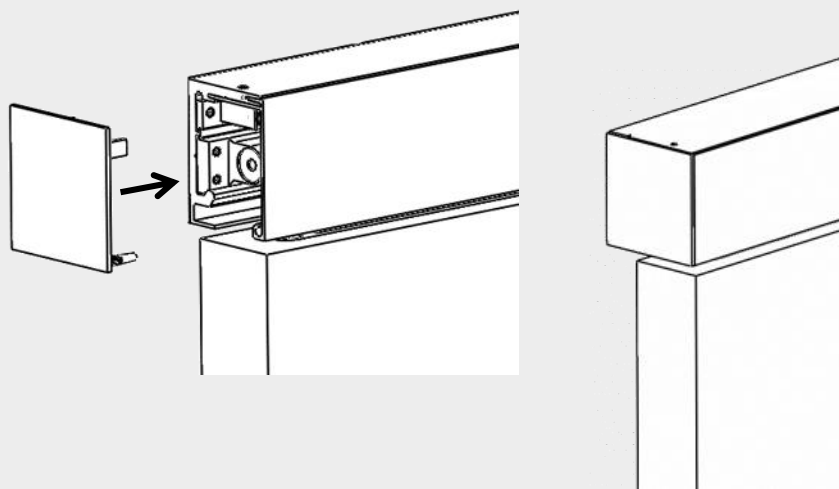

15

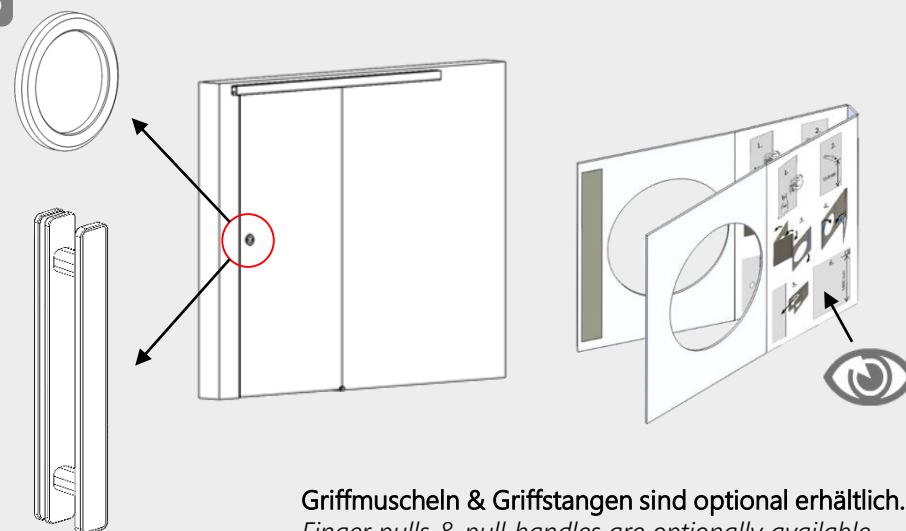

Griffmuscheln & Griffstangen sind optional erhältlich.
Finger pulls & pull handles are optionally available.